

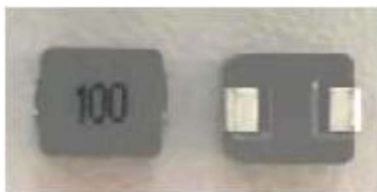

## Power Inductor EBP05 P Series Product Specifications

Document No.	S-10-12-109-01
Revision Date	2022/07/25
Page No.	1/9

### ■ Power Inductor — EBP05 P Series



#### ■ Application

- Note PC power system.
- DC/DC converters.

#### ■ Features

- 100% Lead (Pb)-Free and RoHS compliant.
- High current, low DCR, high efficiency.
- Magnetically shielded structure to accomplish high resolution in EMC protection.
- Operating temperature -40°C~+125°C(Including self - temperature rise) .

### ■ Parts Number Explanation

Example:

<b>EBP</b>	<b>0520</b>	<b>P</b>	<b>R47</b>	<b>M</b>	<b>T</b>	<b>W</b>	<b>Z</b>
<b>Product Type</b>	<b>Size (mm)</b>	<b>Application</b>	<b>Inductance (uH)</b>	<b>Tolerance</b>	<b>Package</b>	<b>Internal Code</b>	<b>Optional</b>
Molding Power Inductor	0520 0530		R47 : 0.47uH R68 : 0.68uH	M : ±20%	T : Taping		Z : Default Code



## Power Inductor EBP05 P Series Product Specifications

Document No.	S-10-12-109-01
Revision Date	2022/07/25
Page No.	2/9

### ■ Standard Electrical Specifications

Part No.	Inductance	DC Resistance	Saturation Current	Heating Rating Current
	L0 (μH)	DCR (mΩ)	Isat (A)	Irms (A)
	±20 %, 100 kHz, 1V	MAX.	TYP.	TYP.
EBP0520P-R22M-TWZ	0.22	5.5	25	15
EBP0520P-R33M-TWZ	0.33	7.3	21.3	12
EBP0520P-R47M-TWZ	0.47	8.6	18	11.5
EBP0520P-R68M-TWZ	0.68	12.4	12.8	10
EBP0520P-1R0M-TWZ	1.0	20	13.7	7
EBP0520P-1R5M-TWZ	1.5	30.5	9.8	5.5
EBP0520P-2R2M-TWZ	2.2	50	9	4.2
EBP0520P-3R3M-TWZ	3.3	76	7.3	3.3
EBP0520P-4R7M-TWZ	4.7	116	5	2.8
EBP0520P-6R8M-TWZ	6.8	150	3.8	2.4
EBP0520P-100M-TWZ	10	199	3.4	2.3
EBP0520P-220M-TWZ	22	390	1.8	1.5
EBP0530P-R22M-TWZ	0.22	4.4	21	15.5
EBP0530P-R33M-TWZ	0.33	5	18	14
EBP0530P-R47M-TWZ	0.47	7.4	16	12
EBP0530P-R68M-TWZ	0.68	12	14	8.5
EBP0530P-R82M-TWZ	0.82	13	12.5	8
EBP0530P-1R0M-TWZ	1.0	14	11	7
EBP0530P-1R5M-TWZ	1.5	25	10	6
EBP0530P-2R2M-TWZ	2.2	35	9	5.5
EBP0530P-3R3M-TWZ	3.3	38	8	5
EBP0530P-4R7M-TWZ	4.7	53	6	4.6
EBP0530P-5R6M-TWZ	5.6	63	4.5	4.25
EBP0530P-6R8M-TWZ	6.8	76.2	4.3	4
EBP0530P-100M-TWZ	10	128	3.5	2.75
EBP0530P-150M-TWZ	15	190	2.6	2.1
EBP0530P-220M-TWZ	22	250	1.7	1.9

### Notes:

1. All test data is referenced to 25 °C ambient
2. Operating temperature range - 40 °C to + 125 °C
3. I<sub>rms</sub> (A):DC current (A) that will cause an approximate ΔT of 40 °C(reference ambient temperature is 25 °C)
4. I<sub>sat</sub>(A):DC current (A) that will cause L<sub>0</sub> to drop approximately 30 %
5. The part temperature (ambient + temp rise) should not exceed 125 °C under worst case operating conditions. Circuit design, component placement, PWB trace size and thickness, airflow and other cooling provisions all affect the part temperature. Part temperature should be verified in the end application.

## ■ Dimensions

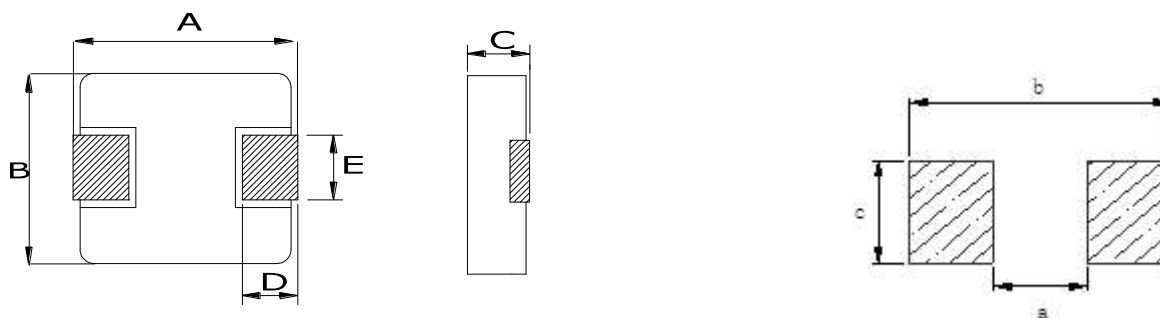

Recommend Land Pattern

Unit: mm

Type	A	B	C	D	E	a typ	b typ	c typ
EBP0520P	5.7±0.3	5.2±0.20	1.8±0.2	1.2±0.2	2.0±0.3	2.2	6.0	2.5
EBP0530P	5.7±0.3	5.2±0.20	2.8±0.2	1.2±0.2	2.0±0.3	2.2	6.0	2.5

## ■ Marking

- The inductor is marked with a 3-digit code

Nominal Inductance	
Example	Nominal Value
1R0	1.0 μH
100	10 μH
101	100 μH



Note : Using Ink for marking



## Power Inductor EBP05 P Series Product Specifications

Document No.	S-10-12-109-01
Revision Date	2022/07/25
Page No.	4/9

### ■ Structure and Components

No.	Components	Material
1	CORE	Carbonyl Powder
2	WIRE	Polyester Wire or equivalent.
3	Clip	100% Pb free solder (Ni + Sn---Plating)
4	paint	Epoxy resin
5	Ink	Halogen-free ketone

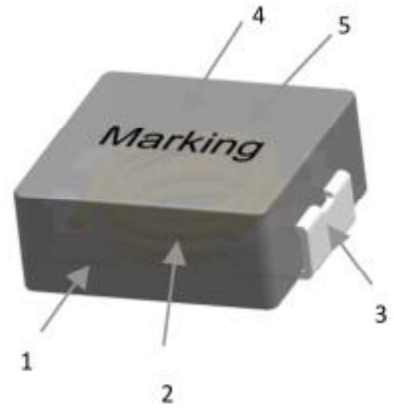



## Power Inductor EBP05 P Series Product Specifications

Document No.	S-10-12-109-01
Revision Date	2022/07/25
Page No.	5/9

### ● Reliability test and requirement

Mechanical Reliability		
Item	Specification and Requirement	Test Method
Solderability	1. No case deformation or change in appearance 2. New solder coverage More than 95%	1. Preheat: 155°C ± 5°C , 60S ± 2S 2. Tin: lead-free. 3. Temperature: 240°C ± 5°C , flux 3.0S ± 0.5S.
Mechanical shock	1. No case deformation or change in appearance 2. $\Delta L/L_0 \leq \pm 10\%$	1. Acceleration: 100G 2. Pulse time: 6ms 3. 3 times in each positive and negative direction of 3 mutual perpendicular directions
Mechanical vibration	1. No case deformation or change in appearance 2. $\Delta L/L_0 \leq \pm 10\%$	1. Reflow: 2times 2. Frequency: 10HZ ~ 55HZ ~ 10HZ, 20 Min/Cycles 3. Amplitude: 1.52 mm 4. Directions: X,Y,Z 5. Time: 12 cycle / direction
Endurance Reliability		
Item	Specification and Requirement	Test Method
Thermal Shock	Inductance change: Within ± 10% Without distinct damage in appearance	1. First -40°C for 30 minutes, last 125°C for 30 minutes as 1 cycle. Go through 1000 cycles. 2. Max transfer time is 3 minutes. 3. Measured at room temperature after placing for 24 ± 2 hours
Humidity Resistance	Inductance change: Within ± 10% Without distinct damage in appearance	1. Reflow 2 times, 2. 85°C, 85%RH, 1000 hours 3. Measured at room temperature after placing for 24 ± 2 hours
Low temperature storage	Inductance change: Within ± 10% Without distinct damage in appearance	1. Temperature: -40 ± 2°C 2. Time: 1000 hours 3. Measured at room temperature after placing for 24 ± 2 hours
High temperature storage	Inductance change: Within ± 10% Without distinct damage in appearance	1. Temperature: +125 ± 2°C 2. Time: 1000 hours 3. Measured at room temperature after placing for 24 ± 2 hours



## Power Inductor EBP05 P Series Product Specifications

Document No.	S-10-12-109-01
Revision Date	2022/07/25
Page No.	6/9

### Recommended Soldering Technologies:

#### (1) Re-flowing Profile

Preheat condition: 150 ~200°C/60~180sec.

Allowed time above 217°C: 80~120sec.

Max temp: 260°C

Max time at max temp: 5 sec.

Solder paste: Sn/3.0Ag/0.5Cu

Allowed Reflow time: 2x max

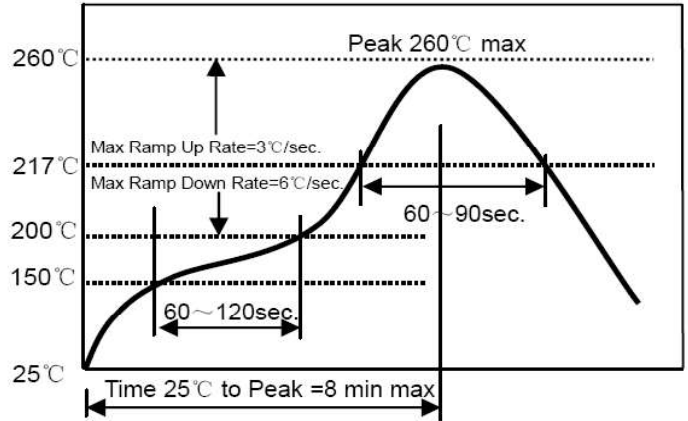

#### (2) Iron Soldering Profile

Iron soldering power: Max. 30W

Pre-heating: 150°C/60sec.

Soldering Tip temperature: 350°C Max.

Soldering time: 3sec. Max.

Solder paste: Sn/3.0Ag/0.5Cu

Max.1 times for iron soldering

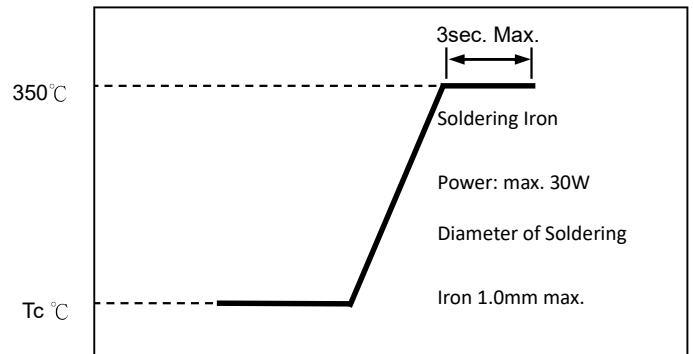

## ■ Packaging Information

### (1) Tape Packaging Dimensions (Unit : mm)

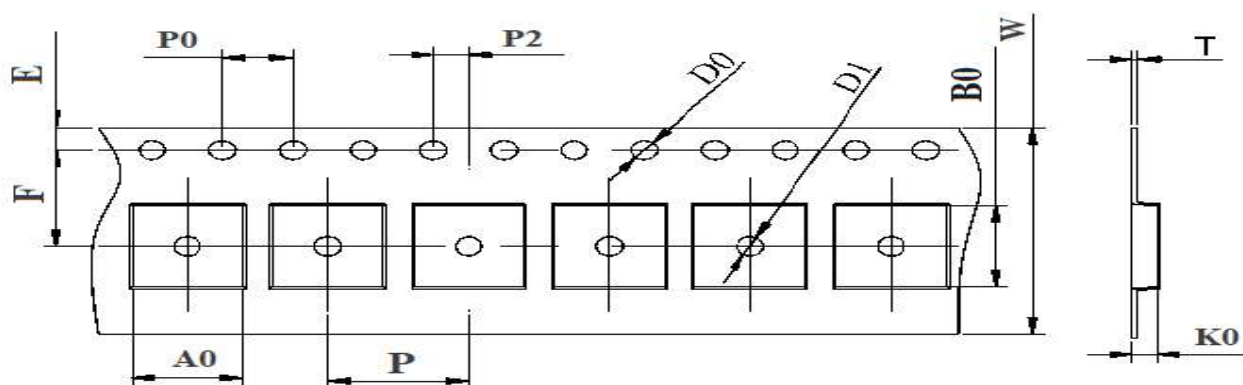

Type	Tape dimensions (mm)											
	W	P	P0	P2	D0	D1	T	A0	B0	K0	E	F
EBP0520P	12±0.3	8±0.1	4±0.1	2±0.1	1.5±0.1	1.5±0.1	0.35±0.05	5.5±0.1	5.9±0.1	2.3±0.1	1.75±0.1	5.5±0.1
EBP0530P	12±0.3	8±0.1	4±0.1	2±0.1	1.5±0.1	1.5±0.1	0.35±0.05	5.5±0.1	5.9±0.1	3.3±0.1	1.75±0.1	5.5±0.1

### (2) Taping Drawings (Unit : mm)

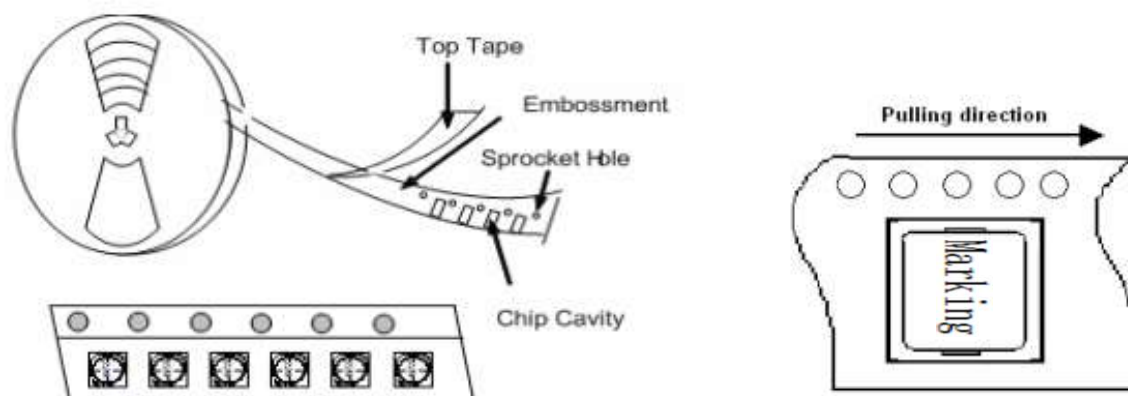

**(3) Reel Dimensions (Unit : mm)**

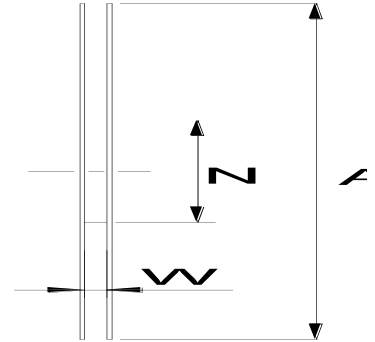
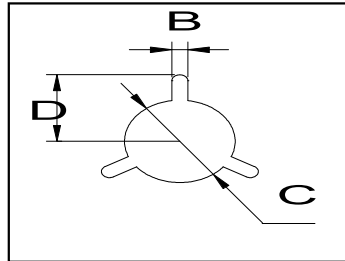
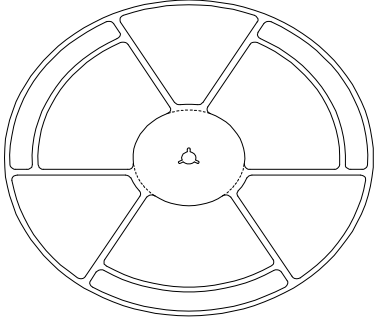

Type	Reel dimensions (mm)					
	A	W	N	B	C	D
EBP0520P	330±2.0	12.8±0.2	97±0.5	2.2±0.5	13.2±0.2	10.75±0.25
EBP0530P	330±2.0	12.8±0.2	97±0.5	2.2±0.5	13.2±0.2	10.75±0.25

**(4) Packaging Quantity(PCS)**

Type	Standard Quantity		
	Reel	Inner box	Carton box
EBP0520P	2000 pcs / reel	4Reel / box (8000 pcs)	4 Middle boxes, (32,000 pcs)
EBP0530P	2000 pcs / reel	4Reel / box (8000 pcs)	4 Middle boxes, (32,000 pcs)

**(5) Peel force of top cover tape**

The peel speed shall be about 300mm/minute

The peel force of top cover tape shall be between 0.1 to 1.3 N

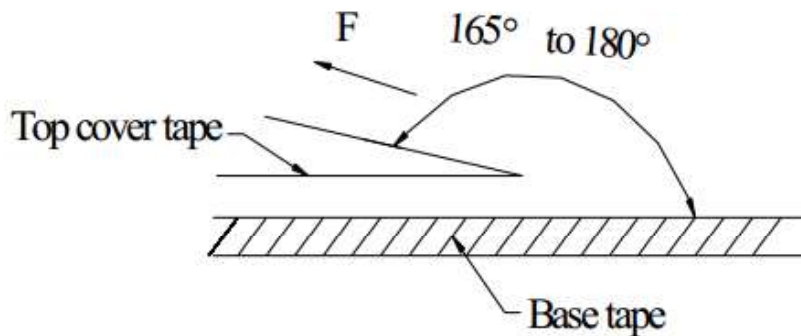





## Power Inductor EBP05 P Series Product Specifications

Document No.	S-10-12-109-01
Revision Date	2022/07/25
Page No.	9/9

### (6) Reel Label

- Label on the reel
  - Everohms part Number.
  - Lot Number
  - Quantity
  - Description
- Shipping Label
  - Customer's part Number
  - Manufacturer's part Number
  - Quantity
  - date code

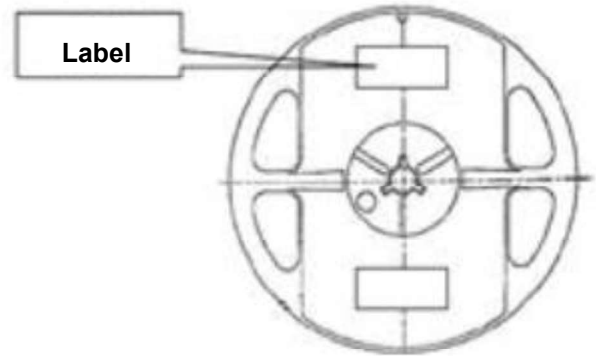

### (7) Inner Box

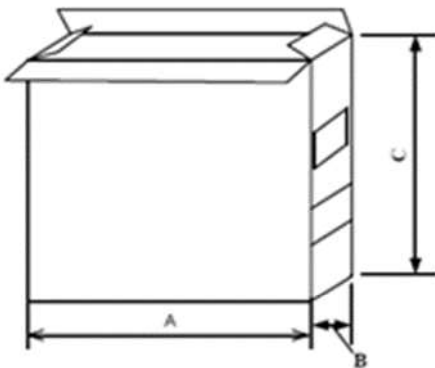

Packaging Type	A (mm)	B (mm)	C (mm)
Inner box	335	70	340

### (8) Carton

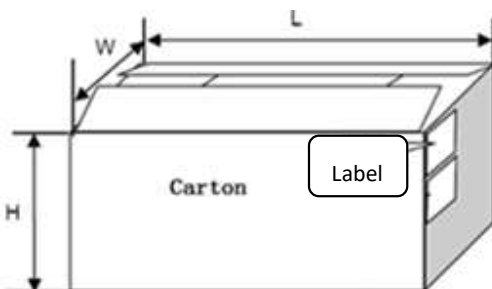

Packaging Type	L (mm)	W (mm)	H (mm)
Carton	360	360	360